

Laboratory Tutorial#4

4.1. Objective: To show how rotary potentiometers mounted on the output and input of a positional control system can generate an error signal.

4.2. Equipment Required: Following equipment is required to perform above task.

<u>Quantity</u>	<u>Apparatus</u>	
1	OU150A	Operation Amplifier Unit
1	PS150E	Power Supply
1	IP150H	Input potentiometer Unit
1	OP150K	Output Potentiometer Unit
1	Multimeter	

4.3. Approximate Time Required: One to two Hours

4.4. Prerequisites: Laboratory Tutorial#1.

4.5. Discussion

In any closed loop system error is calculated by taking the difference of input and output of the system. In this assignment we will use summing amplifier to produce error signal. In setting up the experiment, care has to be taken initially to set the amplifier output to as near zero as possible. If as in figure-4.1 we make V_2 the opposite polarity to V_1 on connecting these voltages to the amplifier the output voltage would be:

$$V_o = -A(V_1 - V_2)$$

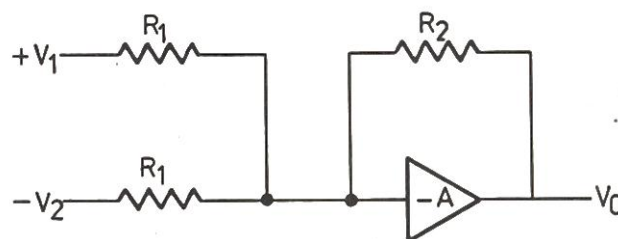

Figure-4.1: Summing Amplifier

We now have a device that can compare two voltages and unless one voltage is exactly the opposite potential of the other, the amplifier will have an output proportional to the difference.

If the inputs V_1 and V_2 are supplied from circular potentiometers with their sliders coupled to a cursor traversing a dial marked in degrees, we can add together the input voltages to form a simple 'error channel' to represent the difference in angular position of the two cursors.

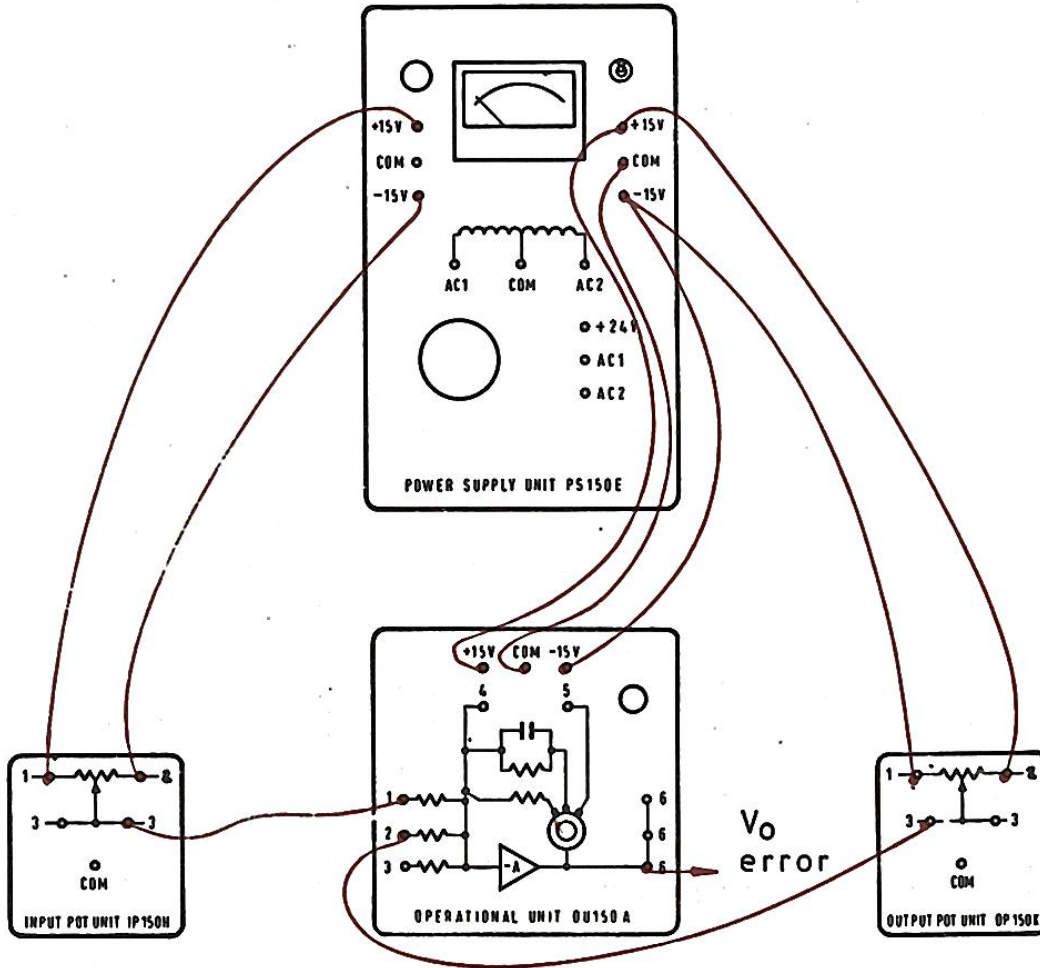

Figure-4.2: Error Channel Set Up

Set up the units as in figure-4.2 but do not yet connect the two amplifier input leads.

4.6 Experimental Set Up

Set the feedback selector switch to 100K Ω resistor. Connect the voltmeter to the output of the Operational amplifier, adjust the zero set so that the output of the amplifier becomes as near to zero as possible.

Before connecting the two sliders into the operational amplifier inputs make certain that

- The resistance between slider (3) and the input terminal (1) is same on both input and output potentiometers for all angular positions. If not, then loosen the dial and make an adjustment.
- As in figure-4.2, connect the rotary potentiometer with opposite polarities. This is very important otherwise the signals when summed will not cancel.

S.No	Input potentiometer		Output potentiometer		$V_1 - V_2$	V_o (Measured)
	θ_i	V_1	θ_o	V_2		

Table-4.1: Error Channel Analysis

Now set the angular position of input and output potentiometers to zero and tabulate the readings, as in table-4.1. Rotate the two cursors to 30° and note the reading again. Repeat the same procedure for some arbitrary angular positions and tabulate the readings.

An important constant in an error channel is the 'error factor' K_e which gives the volts/degrees of misalignment. In a position control system the misalignment would be between input and output shafts, represented in this experiment by the positions of the cursors.

Conclusion/ Comments: